

# X Pro 200

Avery Berkel

Leading Edge Technology for Evolving Retail Needs

## One Solution

Hardware and Software – Designed and built by Avery Berkel

HD touchscreen available in a range of sizes with flexible and optimised UI

Quad-core performance with expandable storage and memory options

Ultra-fast connectivity with Gigabit Ethernet and optional WiFi 6



Labelling

**MXi-Pro**  
Compatible



Production Mode\*



ESL Integration\*



Queue Management



Impact resistant and anti-glare PCAP touchscreen for exceptional durability and clarity



Next generation user interface with industry-leading intuitive design, enhancing productivity and efficiency



Expansive storage for all your HD media, simply switch between product info, promos, or customer messages



UPC, EAN-13, EAN-128, QR codes, DataMatrix, and GS1 DataBar formats, to cover all retail barcode needs



Versatile 2-in-1 printer elevates your brand through logos, graphics, and custom fonts to both promote and inform



Innovative cloud software ecosystem, enhanced with remote connectivity for seamless, efficient system control



Certified 80 Plus energy rating delivers efficient power usage, reducing energy and operational costs

# X Pro 200

Avery Berkel

Leading Edge Technology for Evolving Retail Needs

## Configurable Options

<b>Capacitive Touchscreen</b>	13.3 inch   11.6 inch   10.1 inch
<b>Rear Display</b>	13.3 inch   11.6 inch   10.1 inch
<b>Weighing Capacity</b>	30kg x 5g   15kg AVR   6kg AVR   6kg x 1g
<b>ValuMax</b>	ValuMax   No ValuMax
<b>Storage</b>	120GB   16GB
<b>Memory</b>	8GB   2GB
<b>WiFi</b>	WiFi 6   No WiFi
<b>2-in-1 printer</b>	Label, receipt 70mm wide 150mm/sec Standard cassette
<b>Linerless</b>	Linerless tear option

## Specifications

<b>Processor</b>	Quad-core
<b>Networking</b>	Gigabit Ethernet
<b>Connectivity</b>	4x USB 2
<b>Multimedia</b>	Audio, video, images
<b>Power</b>	100–240 Volt AC 50/60Hz
<b>Operating Environment</b>	-10°C to +40°C   10 to 85% relative humidity
<b>Approvals</b>	UK, EU and OIML

## Software

<b>OS</b>	Linux
<b>Compatibility</b>	Communicates with XT scale networks

## Shipping Specification

<b>Net Weight</b>	12.8kg
<b>Gross Weight</b>	15.1kg
<b>Box Dimensions</b>	575mm W x 545mm D x 310mm H

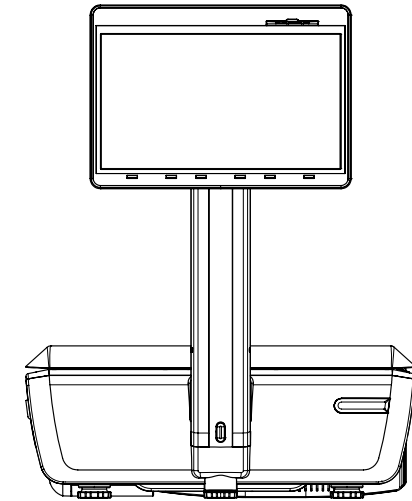
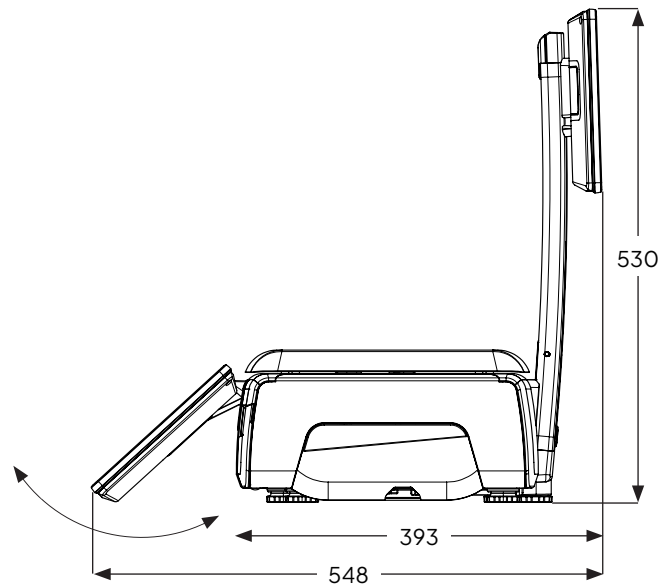

13.3 inch version

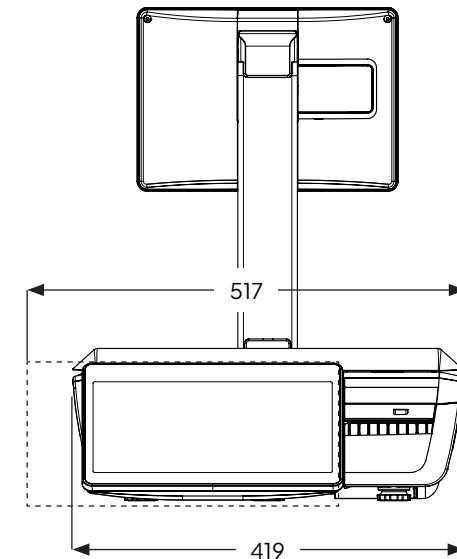

11.6 inch touchscreen option depicted. All measurements in millimetres.